

SP 020 R

MODEL SPIDOGLOSS SP020R ECO	<ul style="list-style-type: none"> • Black ribbed surfaces 	<ul style="list-style-type: none"> • Max. temperature 400°C
	<ul style="list-style-type: none"> • Manual Control 	<ul style="list-style-type: none"> • Glass ceramic



DESCRIPTION

Professional Contact Cooking System with Glass Ceramic plates, suitable for cooking a wide array of different foods, as such: toast, sandwich, meat, fish, vegetables, eggs, etc. High quality cooking result thanks to heat distribution uniformity and use of shock resistance, non-stick, non-porous and impermeable to smells and tastes Glass Ceramic Cooking Surfaces.

High versatility of use thanks to **SHB™ Plus** technology which allows combined heating (contact + infrared) and high cooking Temperature setting.

Up to 60% saving in Preheating Time thanks to **SHB™ Plus**. Up to 60% saving in Energy consumption thanks to the **Protek.Safe™** high efficiency insulation system which eliminates unnecessary energy loss.

STANDARD COOKING FEATURES

SETTINGS:

- Manual Control
- Temperature set: 120 °C – 400 °C.

STANDARD TECHNICAL FEATURES

- **Double Black Ribbed Glass Ceramic cooking plate:**
2 250x250 mm.
- Stainless Steel Case
- Ergonomic Handle
- Self-looking Handle Bracket
- 4 Non-Slip Feets
- Removable Dip Tray
- ON/OFF button and LED light

ACCESSORIES

- **METAL SCRAPER**
Metallic scraper for Glass Ceramic Surfaces (included)
- **SPIDO CLEAN SPRAY DETERGENT**
750 ml Spray Detergent for Glass Ceramic and Steel Surfaces (to be purchased separately)



SP 020 R

Views
Connection positions
Dimensions and Weights
Installation requirements
Power supply

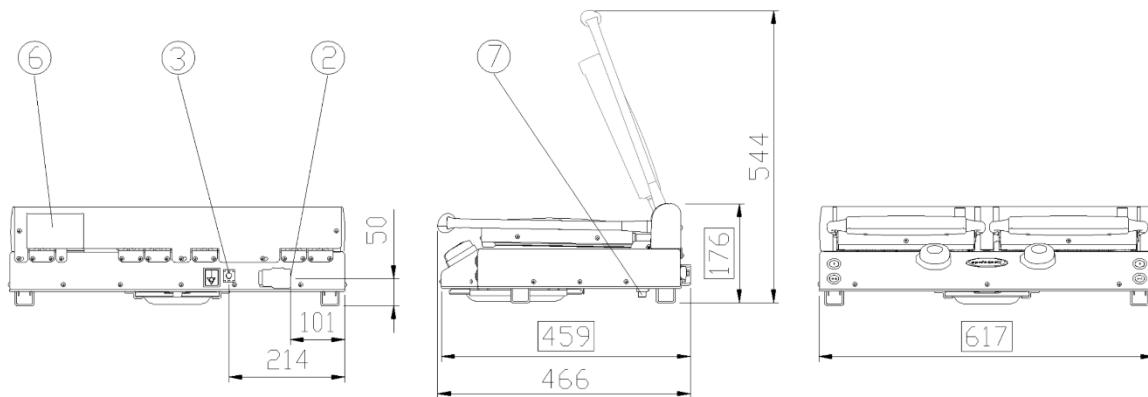

CONNECTION POSITIONS

2	Terminal board power supply
3	Unipotential terminal
6	Technical data plate
7	Safety thermostat

DIMENSIONS AND WEIGHT

Width	617 mm
Depth	459 mm
Height	176 mm
Net Weight	17 Kg

INSTALLATION REQUIREMENTS

Installations must conform to all local electrical systems, specifically minimum wire gauge required for field connection, hydraulic and ventilation codes.

POWER SUPPLY

	STANDARD
Voltage	230 V
Phase	1PH+N+PE
Cycle	50-60 Hz
Power	2 kW
Maximum Amp Draw	13 A
Power cable requirement	H07RN-F 3G 1.5 mm ²
Cord diameter	10 mm
Plug	SCHUKO

SP 020 R

Wiring diagrams

SP 020 R

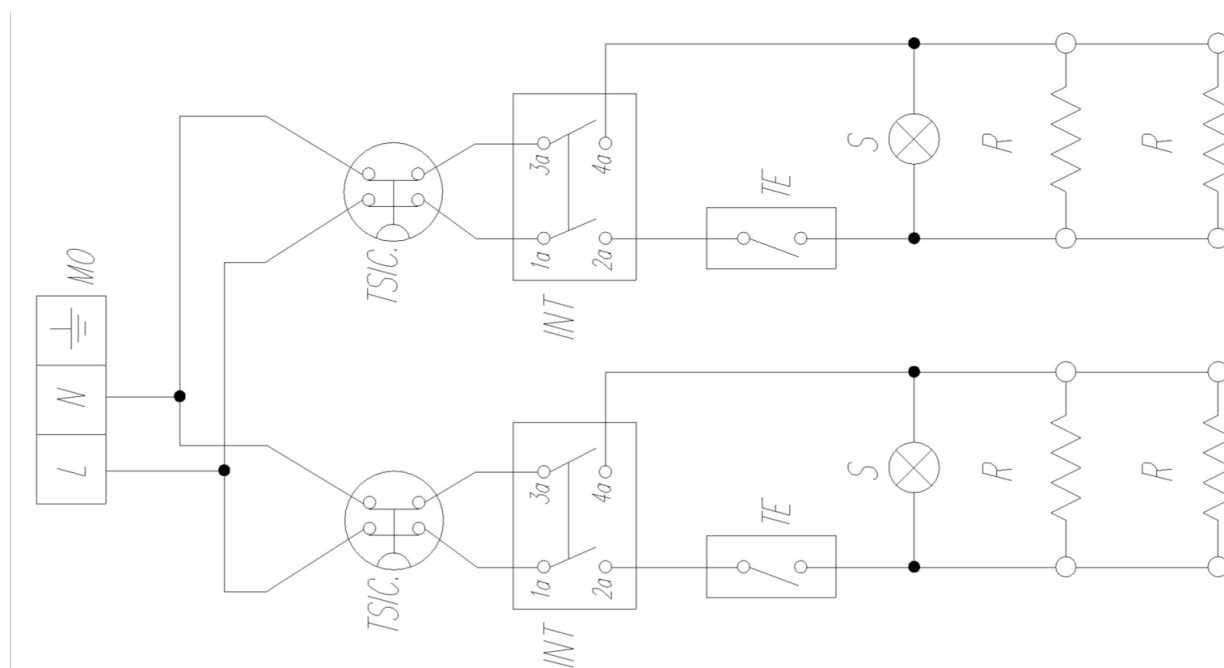

WIRING DIAGRAMS

INT	Switch
MO	Terminal board
R	Heating element
S	Pilot light
TE	Thermostat
TS	Safety thermostat